

HEDGE TRIMMER QUICK START GUIDE



This Auger Torque quick start guide will enable you to get your new product up and running in no time. The complete operators manual is available on the Auger Torque website. To download a copy in pdf format, simply scan the QR code or visit www.augertorque.com.

99-95518011 - ISSUE 1-0

ENGLISH

For warranty purposes this product MUST be registered with Auger Torque within 14 days of purchase by the end user.

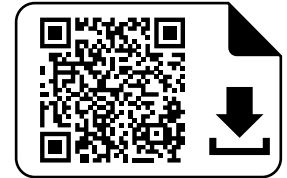

OIL FLOW LIMITATIONS

The Hedge Trimmer attachment requires an absolute minimum of 30 LPM to the attachment at all times to cut a maximum of 25mm diameter foliage. Increase the oil flow accordingly to effectively cut up to 40 mm diameter foliage.

When used with the optional 1 metre Extension, the Hedge Trimmer attachment requires an absolute minimum of 45 LPM.

The minimum hydraulic flow rate needs to be delivered to the attachment regardless of whether the carrier machine is stationary or tracking. When tracking, most excavators take flow from the attachment line and prioritise it to the tracking function. If this results in the attachment line receiving less than the minimum flow rate required, the hedge trimmer will not operate efficiently.

With a lot of excavators, the slewing function does not starve the hydraulic flow to the attachment line to the same severity as the tracking function, which means the operator can use the hedge trimmer effectively by slewing to cut then moving the tracks, stopping and slewing to cut again, repeating this process to complete the task.

MOUNTING THE HEDGE TRIMMER

Mounting - Excavator

Hoses should always be disconnected when fitting, removing or adjusting mounts.

The Hitches and Mounts are connected to the Hedge Trimmer in the same way.

Engage dog gear into one of the three Hedge Trimmer mounts on the rear of the main body (dependent on customer requirements). These mounts allow the hedge trimmer a 360° mounting position.

Once required position is located secure with fixing bolt and washers and tighten to 100Nm.

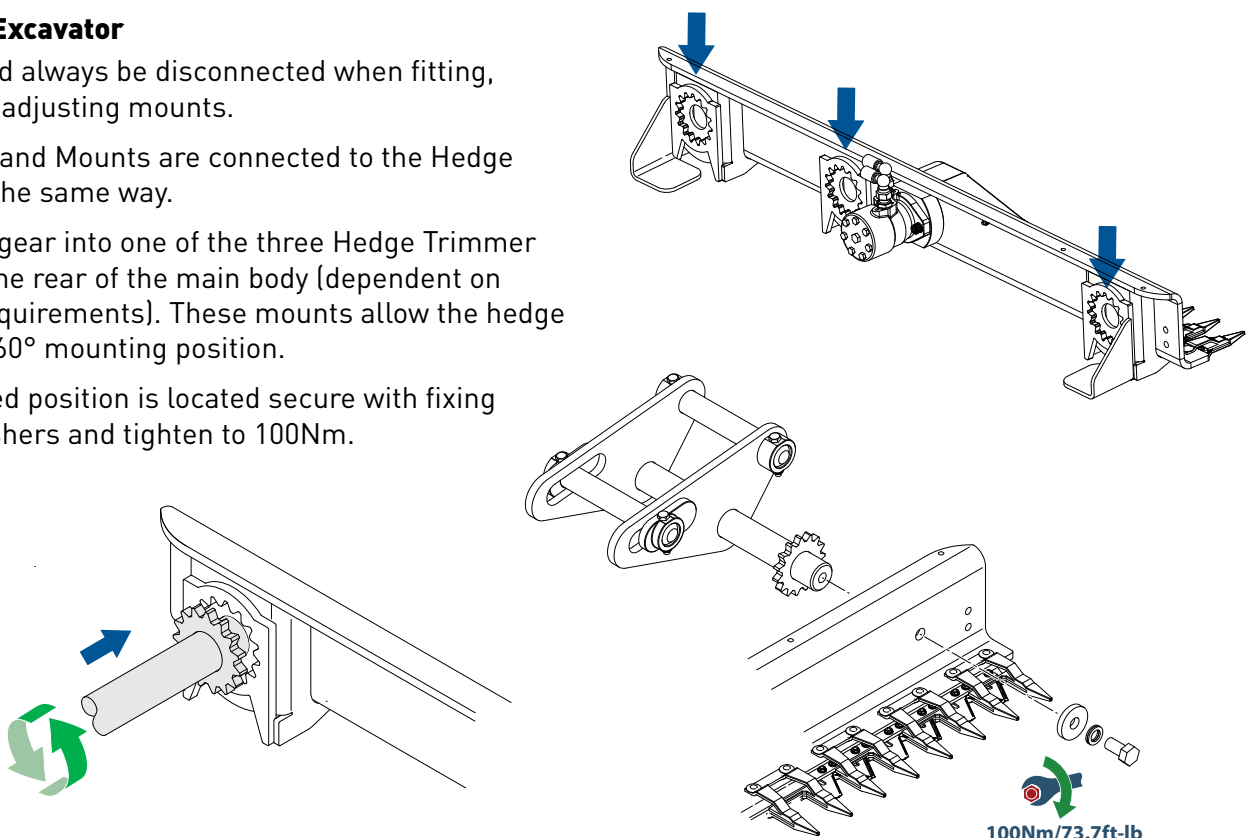

Mounting - Skidsteer and Miniloader Offset Mount

Hoses should always be disconnected when fitting, removing or adjusting.

- Fit offset mount back plate to mounting frame, ensure spacer is fitted between back plate and mount supports tighten to 100Nm.
- Slot the top of the parent machine frame under the top edge of the Mounting Frame or Locating Hooks (A) (refer to parent machine operator's manual).
- Swing the parent machine frame to the vertical position (B).
- Following the parent machine operators manual, ensure that the Mounting Frame is securely locked in place (C).

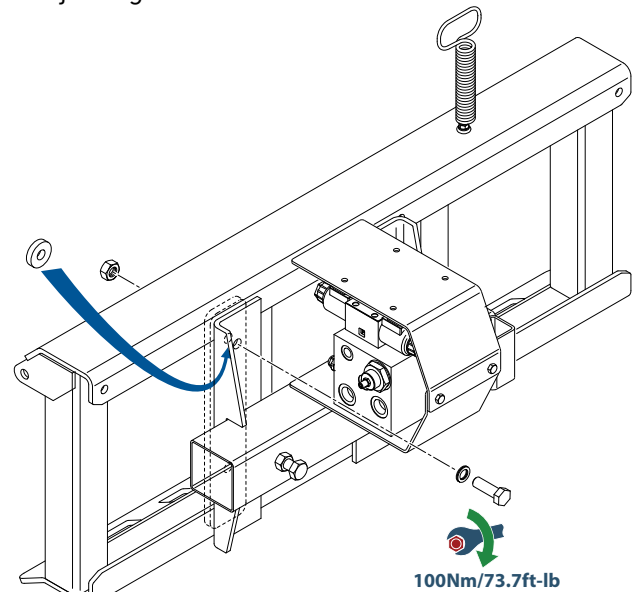
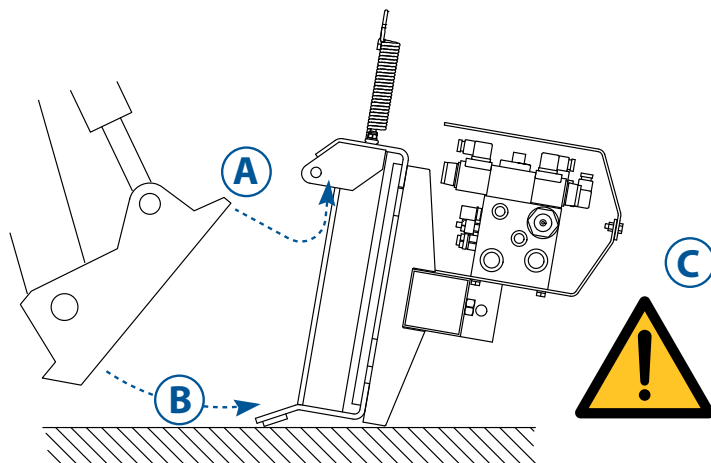

- Slide offset mount body assembly in to the right-hand side of the back plate with the ram uppermost.

NOTE: If the valve block is rotated through 180° the offset mount body can be fitted on the lefthand side dependent on customer requirements.

- Lock body in required position using the three locking screws in the back plate.
- Fit pin and lynch pin to the end of offset mount body.
- Connect hydraulic hoses.

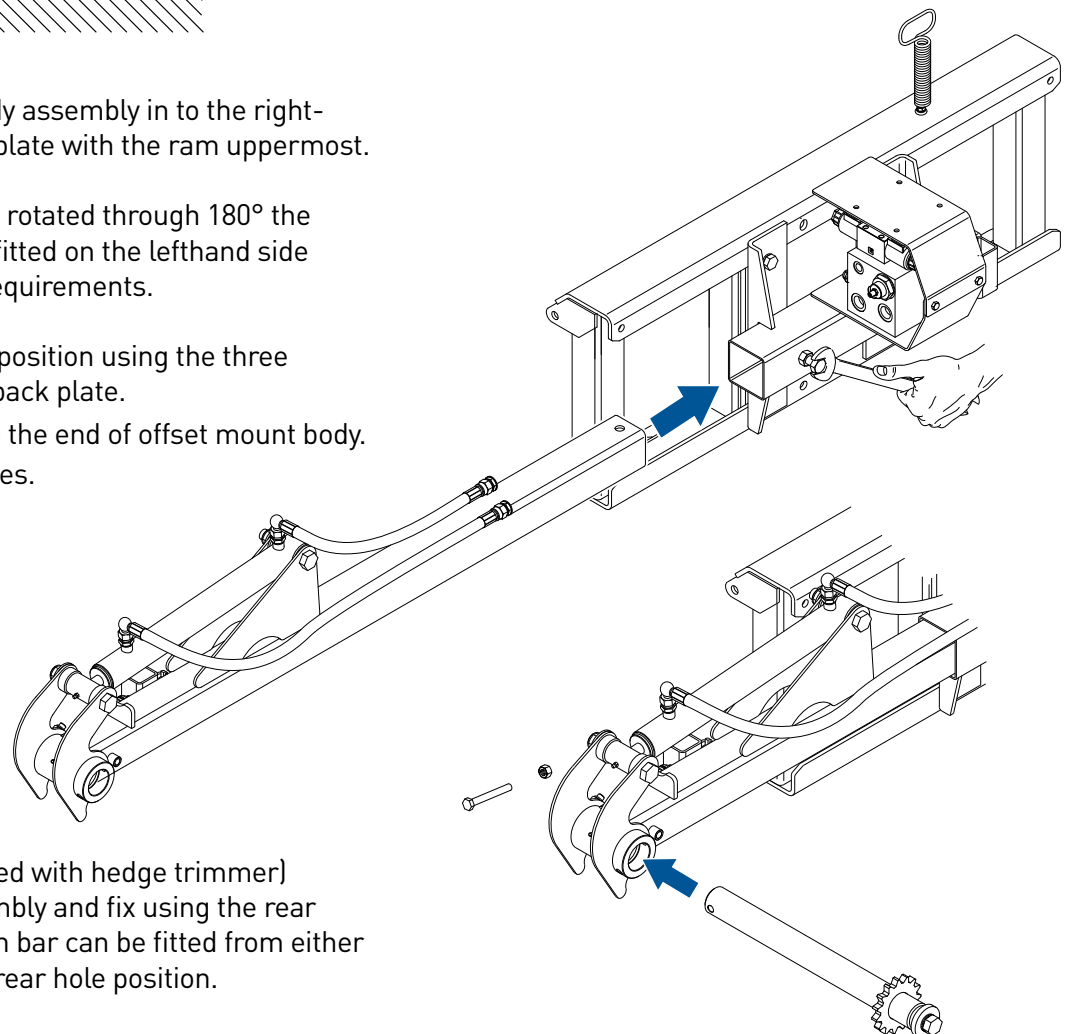

- Push hitch bar (supplied with hedge trimmer) though the body assembly and fix using the rear hole position. The hitch bar can be fitted from either side always using the rear hole position.

HYDRAULIC CONNECTIONS

Auger Torque Hedge Trimmers have been designed for use with specific Auger Torque mounting frames. Provided these are used and maintained correctly, they will provide a safe and reliable method of hedge trimming.

Auger Torque Hedge Trimmers require a 'flow' and 'return' of hydraulic fluid from the parent machine's auxiliary hydraulic power supply to operate. The Hedge Trimmer requires the host machine to be fitted with a two way flow auxiliary circuit. Check with the parent machine dealer for advice.

When fitting hydraulic hoses, ensure that they are tightened to the correct torque for the hose fittings.

When routing hoses from Hedge Trimmer to parent machine ensure hoses are free and clear of blades.

It is critical that the supply of oil is within the stated limits of the Hedge Trimmer.

Check that the rated flow (l/min - gal/min) & pressure (Bar - PSI) of your machine does not exceed the limits shown on the serial plate.

Excavators

The parent machine auxiliary hydraulic connections are normally located near the end of the excavator dipper.

Skidsteer and Miniloaders

The parent machine auxiliary hydraulic connections are normally located near the end of the loader arms.

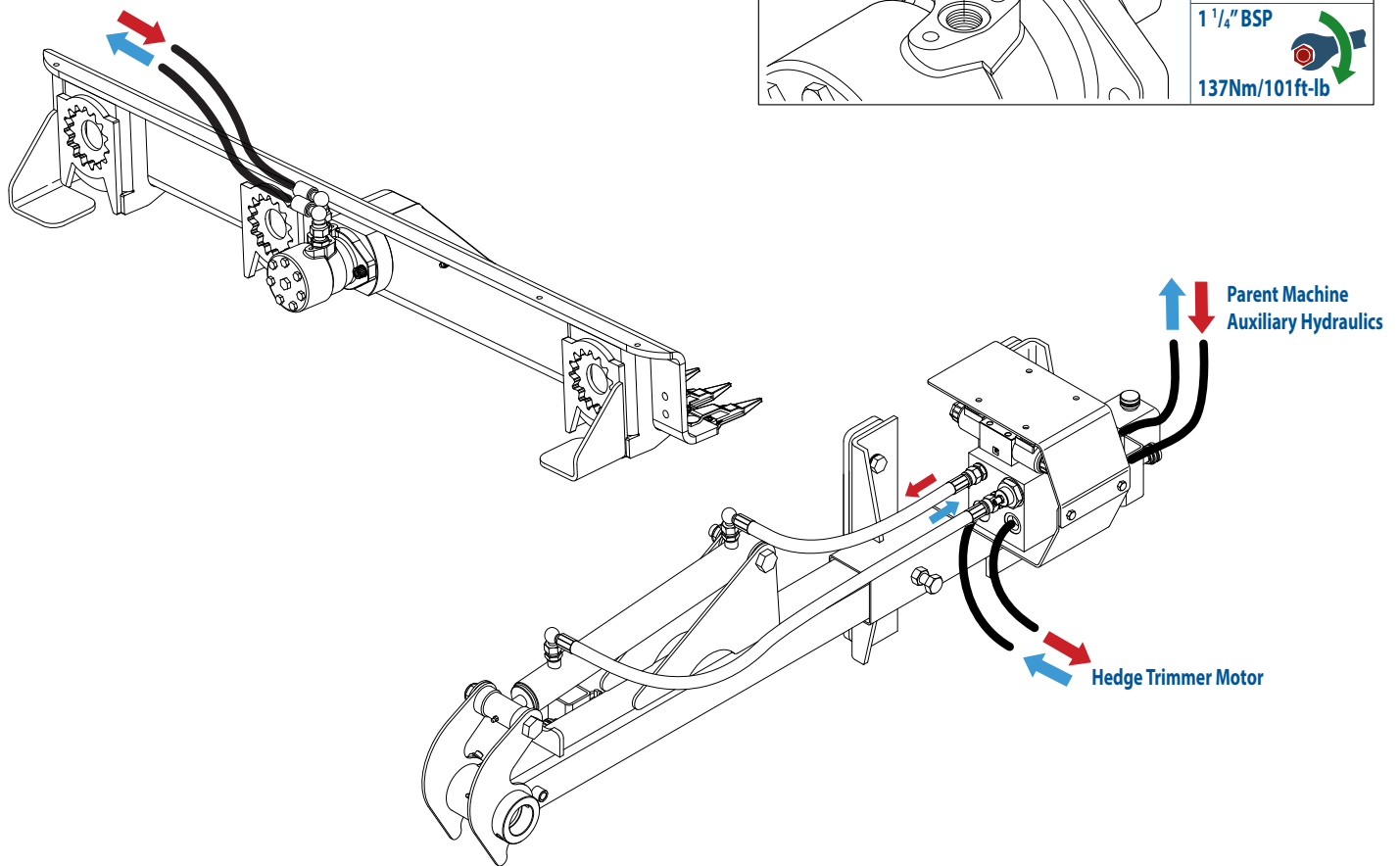

CONTROL BOX

- Mount control box in a suitable position in the operators area so that the toggle switches are accessible.
- Route diverter valve cable along parent machine to the control box in the operator's area. Secure as necessary, ensure cable is free and clear of blades.
- Connect the diverter valve cable plug to the control box plug.
- Connect the control box to the parent machines auxiliary power supply.

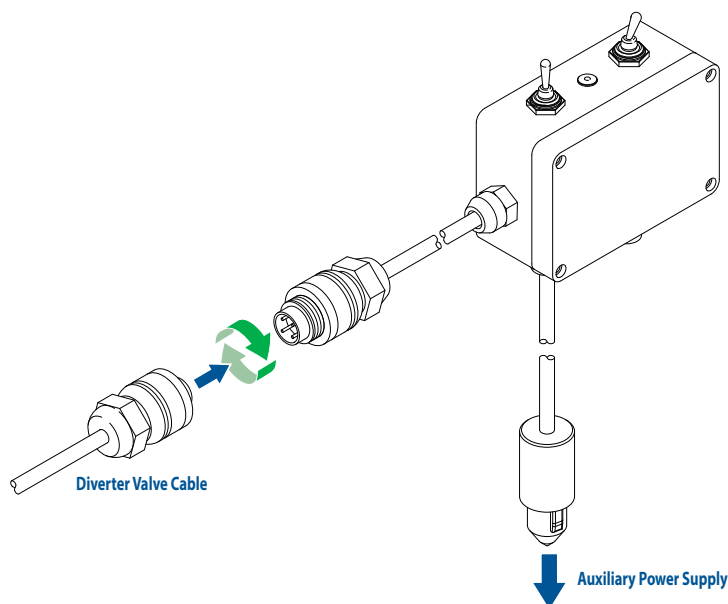

OFFSET MOUNT OPERATION

Switch the control box on, a green light will illuminate. The auxiliary controls on the parent machine can now be used to operate the hedge trimmer.

The toggle switch nearest the valve cable entry is used to adjust the angle of the hedge trimmer from the driver's position.

To change the angle of the trimmer press and hold the toggle switch forward or backwards to change the angle. When the correct angle is achieved release the toggle switch.

